

SIDE PANEL DIMS		
DIMENSION	ITEM	LENGTH/SIZE (mm)
A	TOP FLANGE	
B	SIDE	
C	BOTTOM FLANGE	
D	MATERIAL THICKNESS	
E	HOLE CENTRES	
F	HOLE DIAMETER	
G	ROLLER DEPTH	
H	INSET FROM EDGE	
L	PANEL LENGTH (3990mm MAX)	

MATERIAL / FINISH	
TYPE REQ'D.	CHECK = X
MILD STEEL	
STAINLESS STEEL	
POWDER COAT	
RAL No.	
GALVANISED	

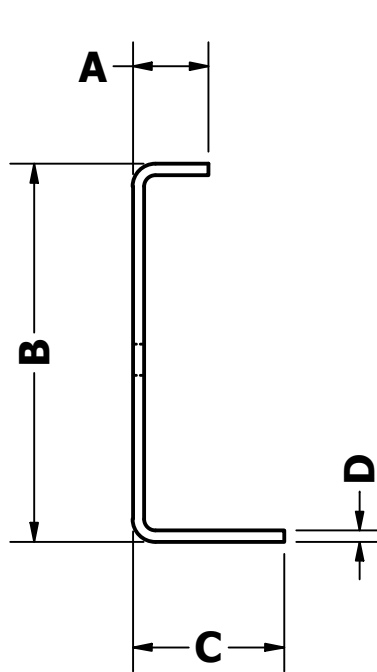

TYPICAL PROFILE
(OTHER PROFILE OPTIONS AVAILABLE ON REQUEST)

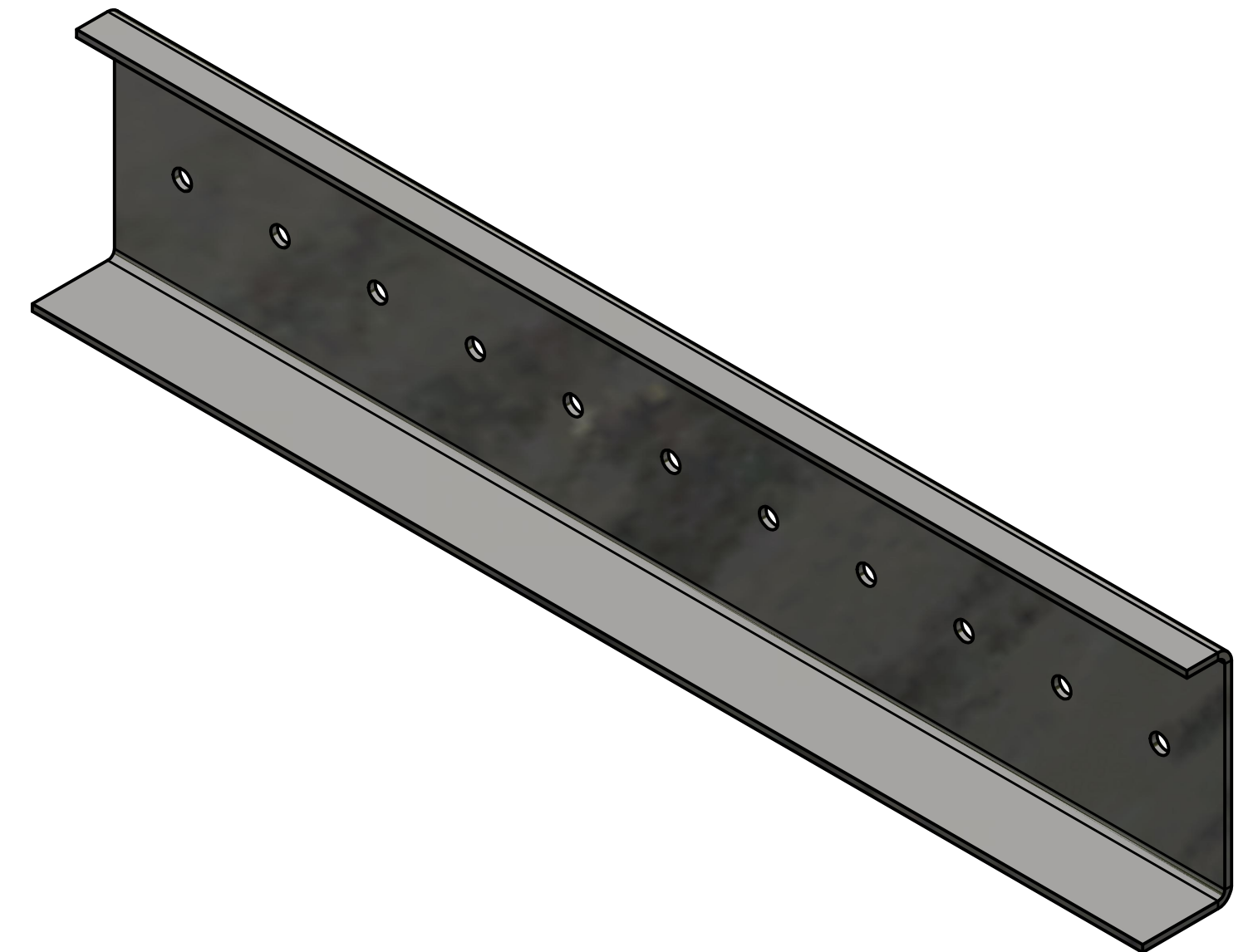
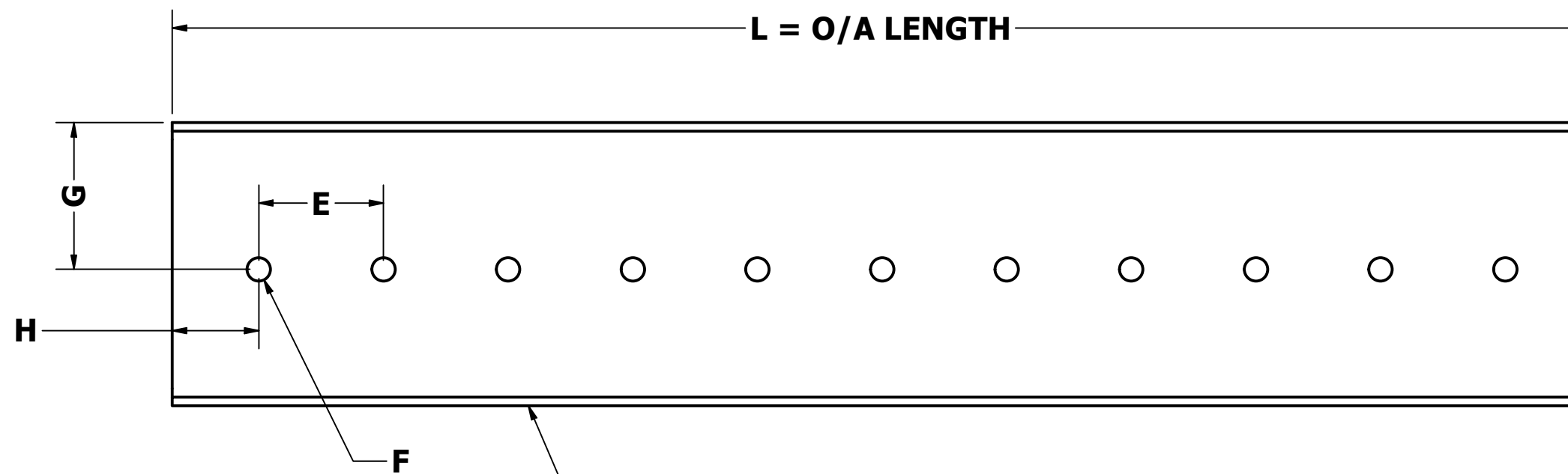

SUPPORT LEG HOLES IN BOTTOM FLANGE ALSO AN OPTION
(STATE AT ENQUIRY STAGE TO DISCUSS SIZE AND CENTRES)

Designed By Barrie Munns	20/11/2020	Rollers UK		
CHECKED				
MD 1001	Est Mass N/A	TITLE Side frame		
Material various		SIZE C	DWG NO SF-001	REV 1
SCALE 1 / 2		WWW.ROLLERSUK.COM		SHEET 1 OF 1